



液动执行器



无锡艾克顿流体科技有限公司

液压式执行器 HYDRAULIC ACTUATOR

液动执行器的调节精度高、响应速度快，能实现高精度控制，传动更平稳可靠，行程调节准确，大扭矩传动，无需减速装置，用于控制 $0^{\circ} \sim 90^{\circ}$ 旋转的阀门及其他同类产品，如蝶阀、球阀、风门、挡板阀、旋塞阀、百叶阀等，可以广泛应用于石油、化工、水处理、船舶、造纸、电站、供热、轻工等个行业中。

Hydraulic actuator with high accuracy, fast response, and can achieve high precision control, the transmission is stable and reliable, and the travel regulation is accurate, low speed large torque transmission without speed reduction device, actuator for controlling the $0^{\circ} \sim 90^{\circ}$ rotary valves and other products, such as butterfly valves, ball valves, air door, flapper valve, plug valve, such as louver valves, can be widely used in petroleum, chemical, water, marine, pulp and paper, power, heating, light industry and other industries.

型号标记 MODEL SIGN

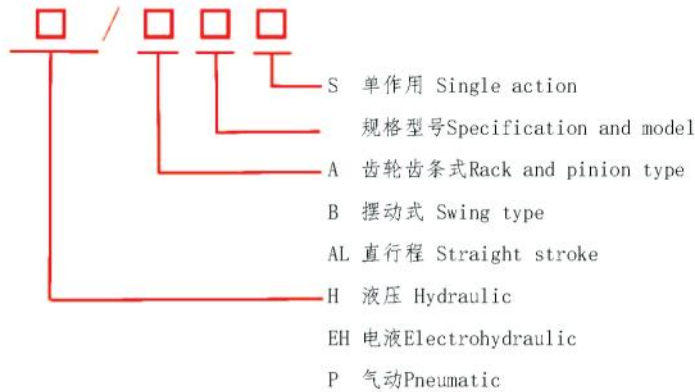

HA双作用执行器

HA DOUBLE ACTING ACTUATOR

技术参数: TECHNICAL SPECIFICATION

型号: ha	Model: ha
工作压力: 11mpa	Working Pressure: 11mpa
旋转角度: $90 \pm 5^{\circ}$	Rotating Angle: $90 \pm 5^{\circ}$
环境温度: $-20^{\circ} \text{c} \sim 80^{\circ} \text{c}$	Ambient Temperature: $-20^{\circ} \text{c} \sim 80^{\circ} \text{c}$
防护等级: ip67 Ip68	Protection Grade: Ip67 Ip68

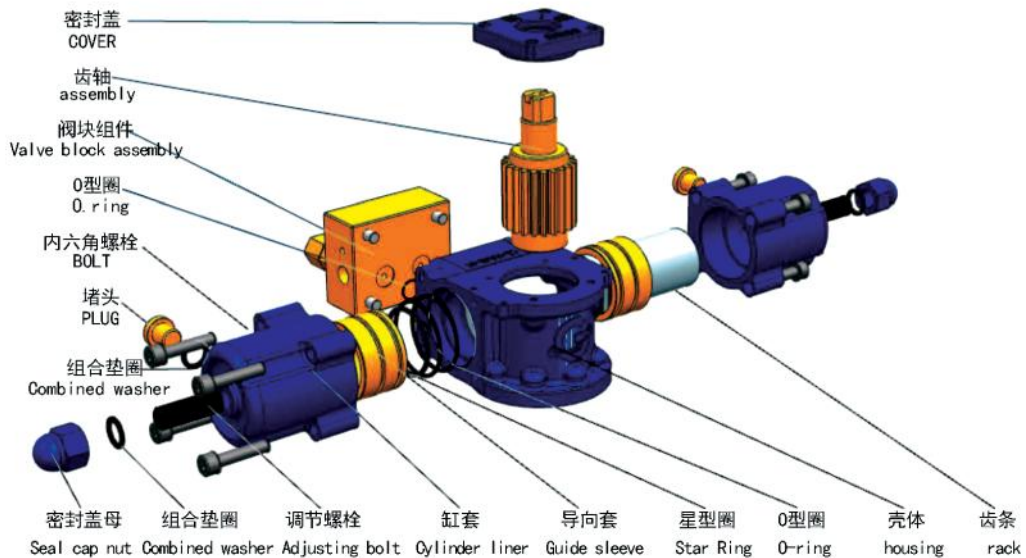



液动执行器

外形尺寸: OUTLINE DIMENSIONS

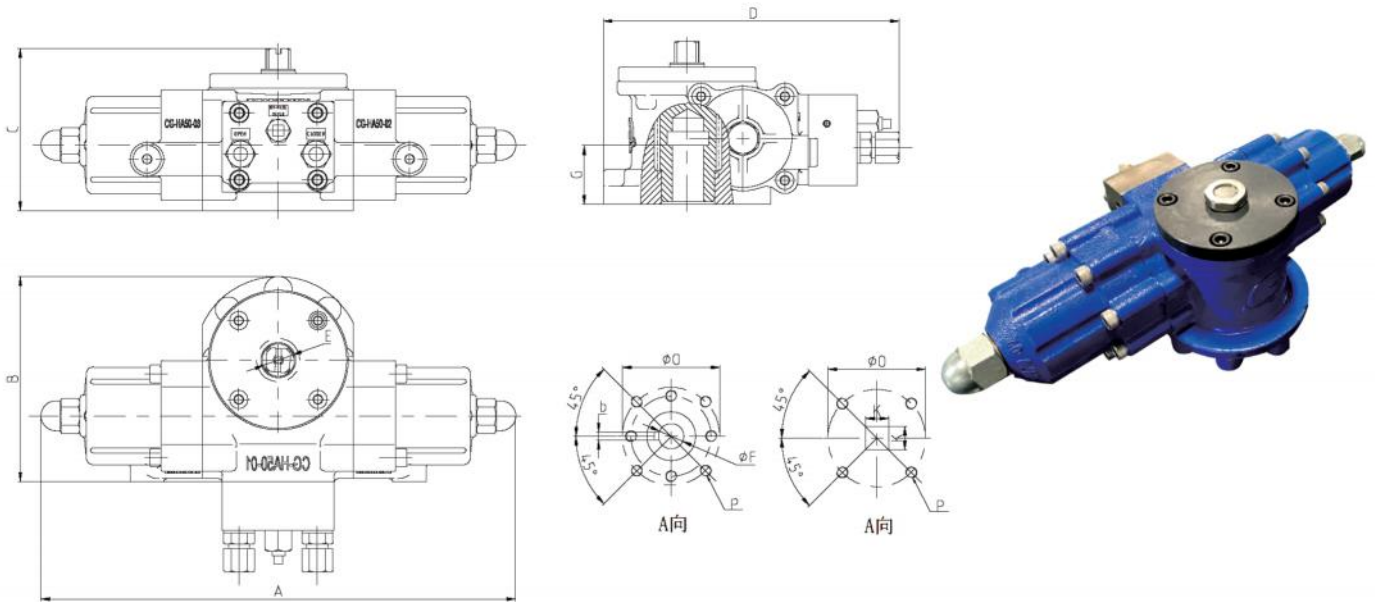

外形及连接尺寸 SHAPE AND CONNECTING DIMENSIONS (mm)

型号 MODEL	HA32	HA40	HA50	HA60	HA70	HA80	HA100	HA130	HA150
ISO FLANGE	F05	F05/F07	F07/F10	F10	F10/F12	F14	F16	F16/F24	F24
A	249	291	400	447	479	564	620	678	818
B	137	116	147	151	185	220	232	292	345
C	84	96	116	152	159	196	216	259	299
D	137	181	212	216	250	285	297	357	419
E	21	20	23.2	31	34	42	42	50	50
G	25	30	40	45	60	65	65	75	120
ϕF	15.8	18	22	28	36	42	50	60	72
ϕO	50/57	50/57/70	70/102/89	102/89	102/125/108	140/159	165/159	165/254	254
P1	4-M6	4-M8	4-M10/M12	4-M10/M12	4-M10/M12	4-M16/M18	4-M18	4-M20/8-M16	8-M16
b	3	6/5	8/6	10/8	10/8	12/10	16/10	18	20
K	14*14	17*17	22*22	27*27	36*36	42*42	46*46	55*55	75*75
Weight/Kg	5	9	19	21	31	45	75	150	195

HAS单作用执行器

HAS SINGLE ACTING ACTUATOR

外形尺寸: OUTLINE DIMENSIONS

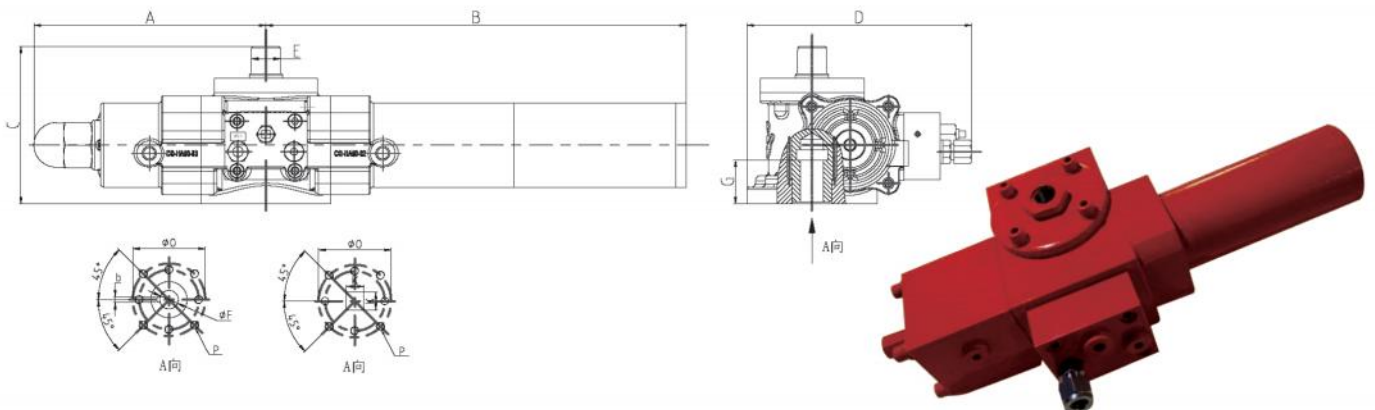

外形及连接尺寸 SHAPE AND CONNECTING DIMENSIONS (mm)

型号 MODEL	HA40S	HA50S	HA60S	HA70S	HA80S	HA100S	HA130S	HA150S
	SA	SA	SA	SA	SA	SA	SA	SA
ISO FLANGE	F05/F07	F07/F10	F10	F10/F12	F14	F16	F16/F24	F24
A	146	170	224	239	283	342	339	409
B	250	265	290	340	441	480	495	675
C	96	116	152	159	196	216	289	299
D	181	212	216	250	250	285	357	419
E	20	24	31	34	42	42	50	50
G	30	40	45	60	65	65	75	120
ΦF	18/15.8/19.05	22/22.2	28/28.6	36/31.8	42/33.34/31.8	50/41.15	60/63.35	72/75
ΦO	50/70/57	70/102/89	102/89	102/125/108	140/159	165/159	165/254	254
P	4-M6/M8	4-M8/M10/M12	4-M10/M12	4-M10/M12	4-M16/M18	4-M20/M18	4-M20/8-M16	8-M16
b	6/5	8/6	10/8	10/8	12/10	16/10	18	20
K	17*17	22*22	27*27	36*36	42*42	46*46	55*55	75*75
NC TORQUE	≤100	≤150	≤230	≤480	≤1000	≤1300/2000*	≤2600/4000*	≤4800/6000*

外形尺寸: OUTLINE DIMENSIONS

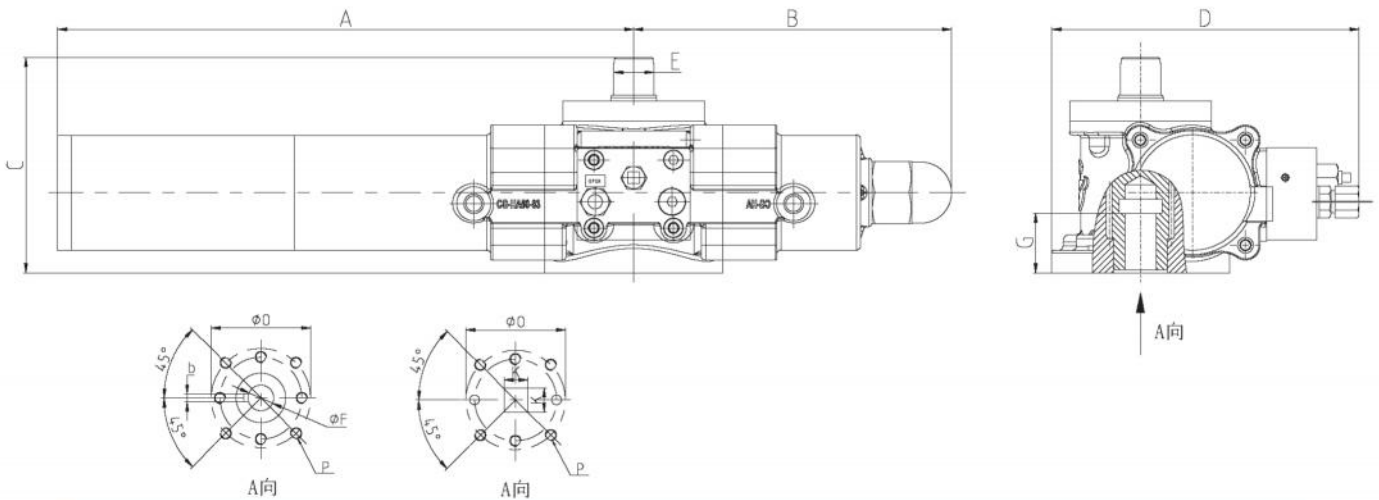

外形及连接尺寸 SHAPE AND CONNECTING DIMENSIONS (mm)

型号 MODEL	HA40S	HA50S	HA60S	HA70S	HA80S	HA100S	HA130S	HA150S
	SA	SA	SA	SA	SA	SA	SA	SA
ISO FLANGE	F05/F07	F07/F10	F10	F10/F12	F14	F16	F16/F24	F24
A	250	265	290	340	441	480	495	675
B	146	170	224	239	283	342	339	409
C	96	116	152	159	196	216	289	299
D	181	212	216	250	250	285	357	419
E	20	24	31	34	42	42	50	50
G	30	40	45	60	65	65	75	120
ΦF	18/15.8/19.05	22/22.2	28/28.6	36/31.8	42/33.34/31.8	50/41.15	60/63.35	72/75
ΦO	50/70/57	70/102/89	102/89	102/125/108	140/159	165/159	165/254	254
P	4-M6/M8	4-M8/M10/M12	4-M10/M12	4-M10/M12	4-M16/M18	4-M20/M18	4-M20/8-M16	8-M16
b	6/5	8/6	10/8	10/8	12/10	16/10	18	20
K	17*17	22*22	27*27	36*36	42*42	46*46	55*55	75*75
NO TORQUE	≤100	≤150	≤230	≤480	≤1000	≤1300/2000*	≤2600/4000*	≤4800/6000*



液动执行器

HB摆动式液压执行器

HB OSCILLATING CYLINDER

主要技术参数 MAIN TECHNICAL PARAMETERS

型号: HB

MODEL: HB

工作压力: 11-13.5MPa

WORKING PRESSURE: 11-13.5MPa

旋转角度: $90 \pm 5^\circ$

ROTATING ANGLE: $90 \pm 5^\circ$

环境温度: $-20^\circ\text{C} \sim 80^\circ\text{C}$

AMBIENT TEMPERATURE: $-20^\circ\text{C} \sim 80^\circ\text{C}$

材质: 球墨铸铁、不锈钢

MATERIAL: Ductile iron, Stainless steel

外形尺寸: OUTLINE DIMENSIONS

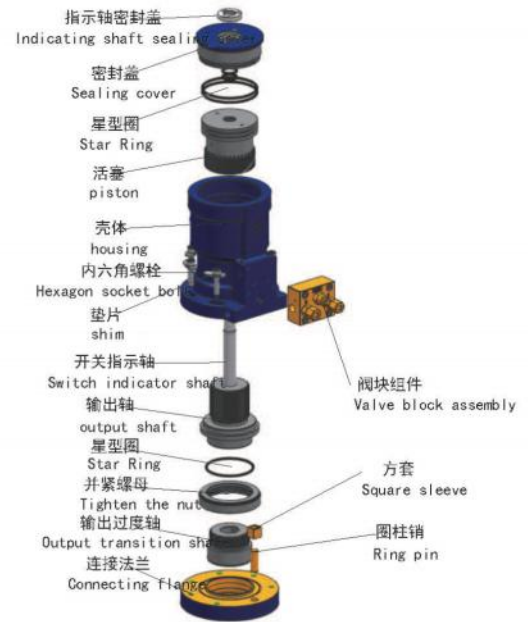
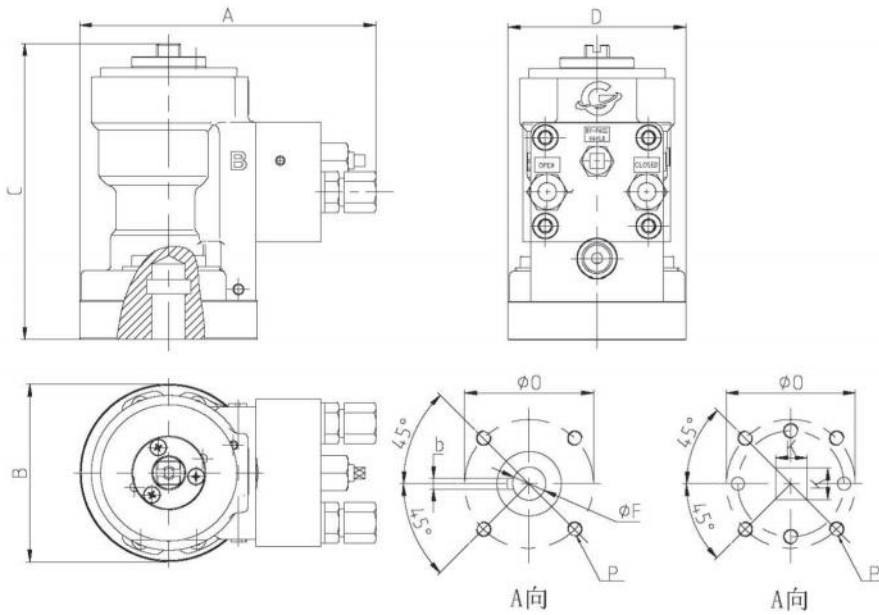

外形及连接尺寸 SHAPE AND CONNECTING DIMENSIONS (mm)

型号 MODEL	HB125	HB300	HB630	HB1200	HB2000	HB4000
	DA	DA	DA	DA	DA	DA
ISO FLANGE	F05/F07	F07/F10	F10/F12	F12/F14	F16	F16/F24
A	96.5	125	140	175	205	280
B	160	174	217.5	254.5	264.5	355.5
C	96.5	125	140	175	205	280
D	96.5	125	140	175	205	280
E	17	17	19	21	21	21
G	30	40	50	50	60	60
ϕF	18/19.05	22/22.2	28/28.6	36/31.8	42/33.34/38	50/60
ϕO	70	102/89	102/89	125/108	140/159	165/216
P	4-M8	4-M10	4-M10	4-M12	4-M16/18	4-M20
b	6/5	8/6	10/8	10	12/10	16/18
K	17*17	22*22	27*27	36*36	46*46	55*55
Wight/Kg	7.5	11	18	29.5	40	85

EHA电液动执行器

EHA ELECTRO-HYDRAULIC ACTUATOR

主要技术参数 MAIN TECHNICAL PARAMETERS

型号: EHA

MODEL: EHA

电制: 220V 50HZ

VOLTAGE: 220V 50HZ

功率: 300W

POWER: 300W

工作压力: 11MPa

WORKING PRESSURE: 11MPa

旋转角度: $90 \pm 5^\circ$

ROTATING ANGLE: 90 ± 5

环境温度: $-20^\circ \text{C} \sim 80^\circ \text{C}$

AMBIENT TEMPERATURE: $-20^\circ \text{C} \sim 80^\circ \text{C}$

防护等级: IP67

PROTECTION GRADE: IP67

外形尺寸: OUTLINE DIMENSIONS

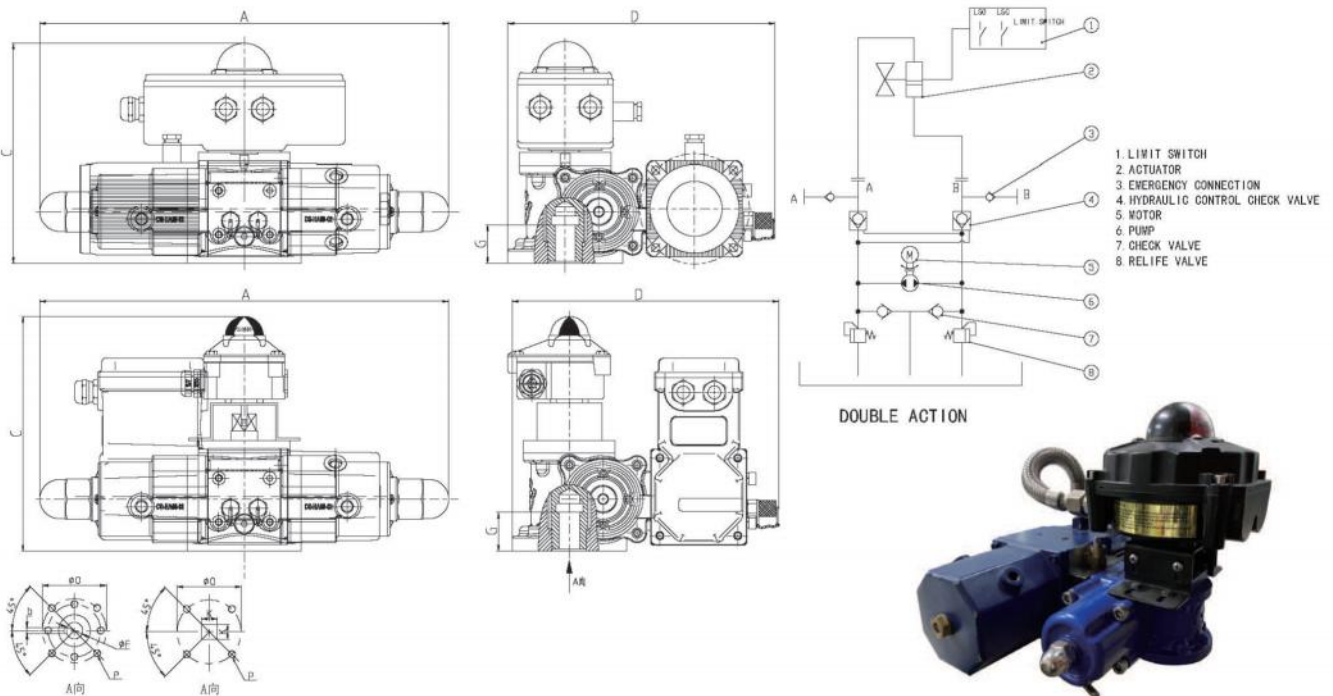

外形及连接尺寸 SHAPE AND CONNECTING DIMENSIONS (mm)

型号 MODEL	EHA40	EHA50	EHA60	EHA70	EHA80	EHA100	EHA130	EHA150
	DA	DA	DA	DA	DA	DA	DA	DA
ISO FLANGE	F05/F07	F07/F10	F10	F10/F12	F14	F16	F16/F24	F24
A	291	400	447	479	554	620	678	818
B	209	223	240	258	280	299	336	359
C	264	272	292	326	360	388	432	494
D	264	272	292	326	360	388	432	494
G	30	40	45	60	65	65	75	120
ØF	18/15.8/19.05	22/22.2	28/28.6	36/31.8	42/33.34/31.8	50/41.15	60/63.35	72/75
ØO	50/70/57	70/102/89	102/89	102/125/108	140/159	165/159	165/254	254
P	4-M6/M8	4-M8/M10/M12	4-M10/M12	4-M10/M12	4-M16/M18	4-M20/M18	4-M20/8-M16	8-M16
b	6/5	8/6	10/8	10/8	12/10	16/10	18	20
K	17*17	22*22	27*27	36*36	42*42	46*46	55*55	75*75



液动执行器

EHAS电液动执行器

EHAS ELECTRO-HYDRAULIC ACTUATOR

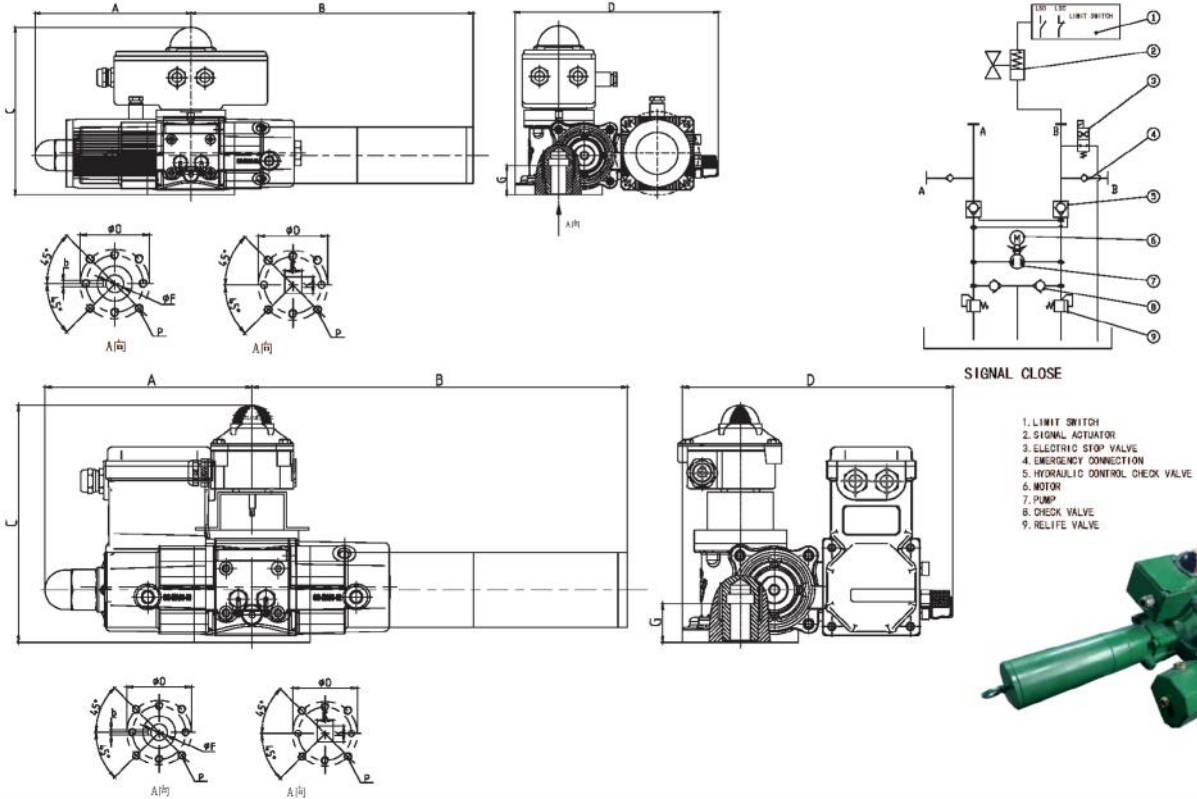

外形及连接尺寸 SHAPE AND CONNECTING DIMENSIONS (mm)

型号 MODEL	EHA40S	EHA50S	EHA60S	EHA70S	EHA80S	EHA100S	EHA130S	EHA150S
	SA	SA	SA	SA	SA	SA	SA	SA
ISO FLANGE	F05/F07	F07/F10	F10	F10/F12	F14	F16	F16/F24	F24
A	146	170	224	239	283	342	339	409
B	250	265	290	340	441	460	495	675
C	209	223	240	258	280	299	336	359
D	264	272	292	326	360	388	432	494
G	30	40	45	60	65	65	75	120
ϕF	18/15.8/19.05	22/22.2	28/28.6	36/31.8	42/33.34/31.8	50/41.15	60/63.35	72/75
ϕO	50/70/57	70/102/89	102/89	102/125/108	140/159	165/159	165/254	254
P	4-M6/M8	4-M8/M10/M12	4-M10/M12	4-M10/M12	4-M16/M18	4-M20/M18	4-M20/8-M16	8-M16
b	6/5	8/6	10/8	10/8	12/10	16/10	18	20
K	17*17	22*22	27*27	36*36	42*42	46*46	55*55	75*75
NC TORQUE	≤100	≤150	≤230	≤480	≤1000	≤1300/2000*	≤2600/4000*	≤4800/6000*

EHB电液动执行器

EHB ELECTRO-HYDRAULIC ACTUATOR

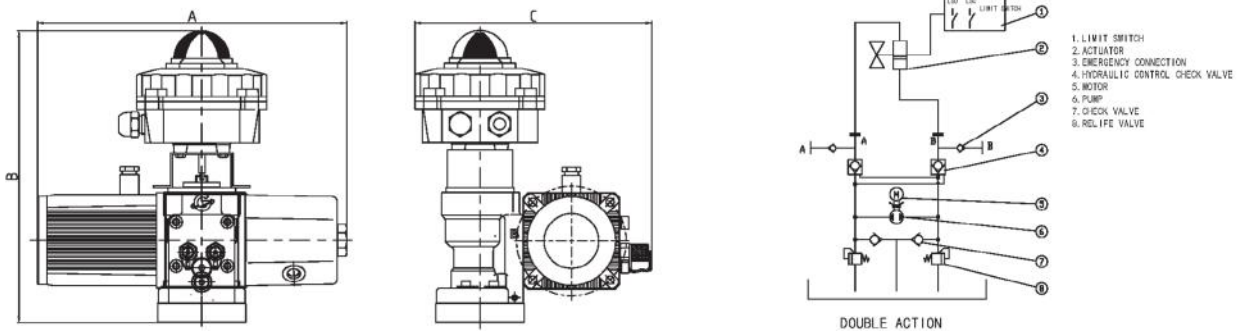



液动执行器

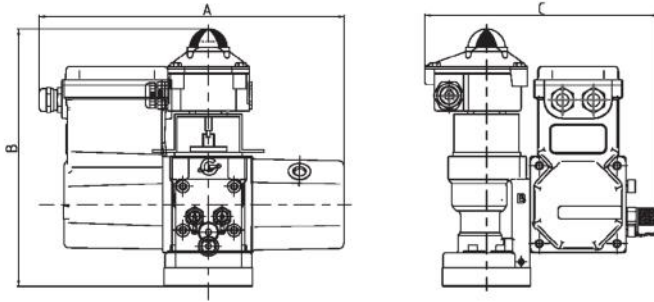

外形及连接尺寸 SHAPE AND CONNECTING DIMENSIONS (mm)

型号 MODEL	HB125	HB300	HB630	HB1200	HB2000	HB4000
	DA	DA	DA	DA	DA	DA
ISO FLANGE	F05/F07	F07	F10	F12	F14	F16
A	338	338	338	338	338	338
B	320	340	380	418	427	522
C	259	271	282	316	337	400
F	18/19.05	22/22.2	28/28.6	31.8/36	33.34/38/42	41.2/50
O	70	70/89	102/89	125/108	140/159	165/159/216
P1	4-M6/M8	4-M10/M12	4-M10/M12	4-M12	4-M16/M18	4-M18/M20
b	6/5	8/6	10/8	10/8	10/12	10/16
K	17*17	22*22	24*24	27*27	36X36	42X42

HAL 液压直行程配阀门系列规格表

HAL HYDRAULIC LINEAR MOTION VALVE SERIES

液压截止阀 HYDRAULIC STOP VALVE

主要技术参数 MAIN TECHNICAL PARAMETERS

型号: HAL

MODEL: HAL

工作压力: 11-13.5MPa

WORKING PRESSURE: 11-13.5MPa

环境温度: -20°C~80°C

AMBIENT TEMPERATURE: -20°C~80°C

执行器材质: 铸钢、不锈钢

ACTUATOR MATERIAL: CAST STEEL, Stainless steel

防护等级: IP67 IP68

Protection Grade: IP67 IP68

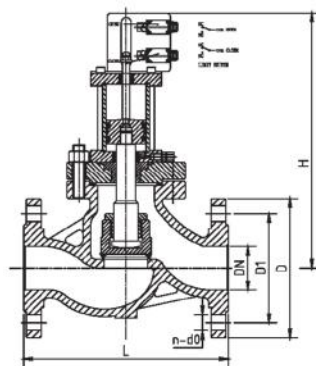
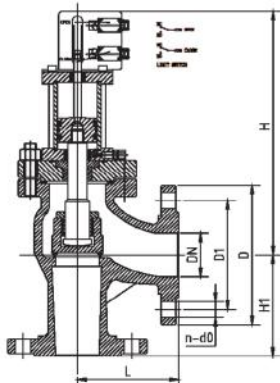



液动执行器

外形及连接尺寸 SHAPE AND CONNECTING DIMENSIONS (mm)

通径DN	结构尺寸 CONSTRUCTION DIMENSTON						法兰 FLANGE								液压执行器 HYDRAULIC ACTUATOR
	L		≈H		H1	∅	GB2506-2005 PN10				JIS 10K				
	A TYPE	B TYPE	A TYPE	B TYPE	B TYPE		D	D1	n	d0	D	D1	n	d0	
DN20	150	95	635	650	95	200	105	75	4	14	100	75	4	15	HAL40
DN25	160	100	640	635	100	200	115	85	4	18	125	90	4	19	HAL40
DN32	180	105	650	640	105	200	140	100	4	18	135	100	4	19	HAL40
DN40	200	115	660	655	115	200	150	110	4	18	140	105	4	19	HAL40
DN50	230	125	670	660	125	200	165	125	4	18	155	120	4	19	HAL40
DN65	290	145	680	675	145	200	185	145	4	18	175	140	4	19	HAL40
DN80	310	155	690	680	155	200	200	160	8	18	185	150	8	19	HAL63
DN100	350	175	705	700	175	250	220	180	8	18	210	175	8	19	HAL63
DN125	400	200	720	710	200	280	250	210	8	18	250	210	8	23	HAL63
DN150	480	225	760	755	225	320	285	240	8	22	280	240	8	23	HAL63
DN200	600	275	815	805	275	360	340	295	8	22	330	290	12	23	HAL80
DN250	730	325	860	840	325	450	395	350	12	22	400	355	12	25	HAL100
DN300	850	375	910	900	375	500	445	400	12	22	445	400	16	25	HAL130

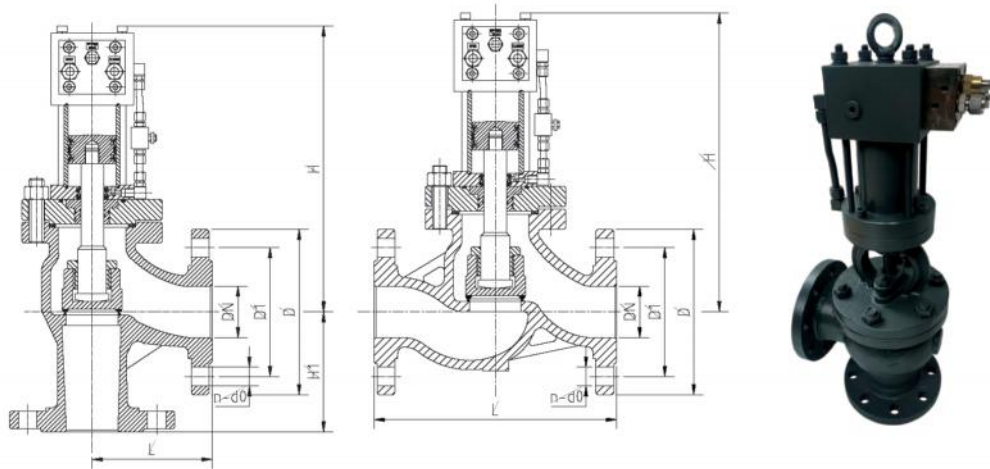

外形及连接尺寸 SHAPE AND CONNECTING DIMENSIONS (mm)

通径DN	结构尺寸 CONSTRUCTION DIMENSTON					法兰 FLANGE								液压执行器 HYDRAULIC ACTUATOR
	L		≈H		H1	GB2506-2005 PN10				JIS 10K				
	A TYPE	B TYPE	A TYPE	B TYPE	B TYPE	D	D1	n	d0	D	D1	n	d0	
DN20	150	95	440	435	95	105	75	4	14	100	75	4	15	HAL40
DN25	160	100	450	440	100	115	85	4	18	125	90	4	19	HAL40
DN32	180	105	455	445	105	140	100	4	18	135	100	4	19	HAL40
DN40	200	115	470	460	115	150	110	4	18	140	105	4	19	HAL40
DN50	230	125	475	465	125	165	125	4	18	155	120	4	19	HAL40
DN65	290	145	485	480	145	185	145	4	18	175	140	4	19	HAL40
DN80	310	155	495	485	155	200	160	8	18	185	150	8	19	HAL63
DN100	350	175	510	505	175	220	180	8	18	210	175	8	19	HAL63
DN125	400	200	525	515	200	250	210	8	18	250	210	8	23	HAL63
DN150	480	225	535	530	225	285	240	8	22	280	240	8	23	HAL63
DN200	600	275	570	560	275	340	295	8	22	330	290	12	23	HAL80
DN250	730	325	585	565	325	395	350	12	22	400	355	12	25	HAL100
DN300	850	375	605	595	375	445	400	12	22	445	400	16	25	HAL130

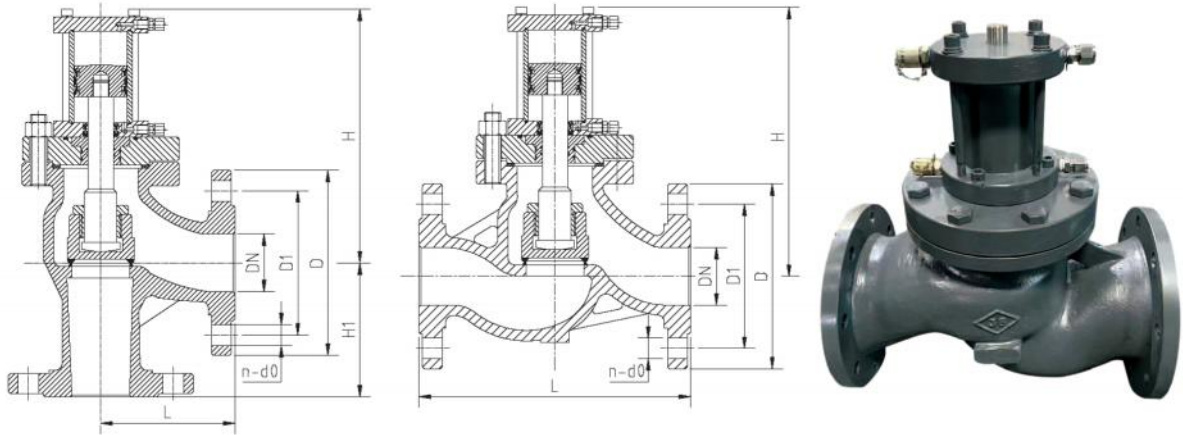

外形及连接尺寸 SHAPE AND CONNECTING DIMENSIONS (mm)

通径 DN	结构尺寸 CONSTRUCTION DIMENSTON					法兰 FLANGE								液压执行器 HYDRAULIC ACTUATOR
	L		≈H			GB2506-2005 PN10				JIS 10K				
	A TYPE	B TYPE	A TYPE	B TYPE	B TYPE	D	D1	n	d0	D	D1	n	d0	
DN20	150	95	385	380	95	105	75	4	14	100	75	4	15	HAL40
DN25	160	100	390	385	100	115	85	4	18	125	90	4	19	HAL40
DN32	180	105	400	390	105	140	100	4	18	135	100	4	19	HAL40
DN40	200	115	415	405	115	150	110	4	18	140	105	4	19	HAL40
DN50	230	125	420	410	125	165	125	4	18	155	120	4	19	HAL40
DN65	290	145	430	425	145	185	145	4	18	175	140	4	19	HAL40
DN80	310	155	440	430	155	200	160	8	18	185	150	8	19	HAL63
DN100	350	175	455	450	175	220	180	8	18	210	175	8	19	HAL63
DN125	400	200	470	460	200	250	210	8	18	250	210	8	23	HAL63
DN150	480	225	480	475	225	285	240	8	22	280	240	8	23	HAL63
DN200	600	275	515	505	275	340	295	8	22	330	290	12	23	HAL80
DN250	730	325	530	510	325	395	350	12	22	400	355	12	25	HAL100
DN300	850	375	550	540	375	445	400	12	22	445	400	16	25	HAL130

手液动截止阀 HAND HYDRAULIC CUT-OFF VALVE

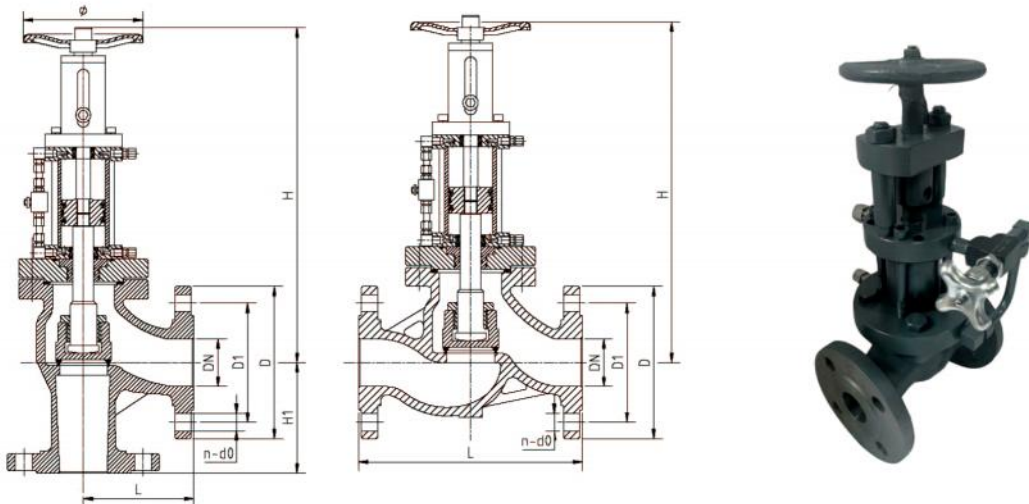



液动执行器

外形及连接尺寸 SHAPE AND CONNECTING DIMENSIONS (mm)															
通径 DN	结构尺寸 CONSTRUCTION DIMENSTON						法兰 FLANGE								液压执行器 HYDRAULIC ACTUATOR
	L		≈H		H1	φ	GB2506-2005 PN10				JIS 10K				
	A TYPE	B TYPE	A TYPE	B TYPE	B TYPE		D	D1	n	d0	D	D1	n	d0	
DN20	150	95	635	650	95	200	105	75	4	14	100	75	4	15	HAL40
DN25	160	100	640	635	100	200	115	85	4	18	125	90	4	19	HAL40
DN32	180	105	650	640	105	200	140	100	4	18	135	100	4	19	HAL40
DN40	200	115	660	655	115	200	150	110	4	18	140	105	4	19	HAL40
DN50	230	125	670	660	125	200	165	125	4	18	155	120	4	19	HAL40
DN65	290	145	680	675	145	200	185	145	4	18	175	140	4	19	HAL40
DN80	310	155	690	680	155	200	200	160	8	18	185	150	8	19	HAL63
DN100	350	175	705	700	175	250	220	180	8	18	210	175	8	19	HAL63
DN125	400	200	720	710	200	280	250	210	8	18	250	210	8	23	HAL63
DN150	480	225	760	755	225	320	285	240	8	22	280	240	8	23	HAL63
DN200	600	275	815	805	275	360	340	295	8	22	330	290	12	23	HAL80
DN250	730	325	860	840	325	450	395	350	12	22	400	355	12	25	HAL100
DN300	850	375	910	900	375	500	445	400	12	22	445	400	16	25	HAL130

液压单作用截止阀 HYDRAULIC SINGLE ACTING CUT-OFF VALVE

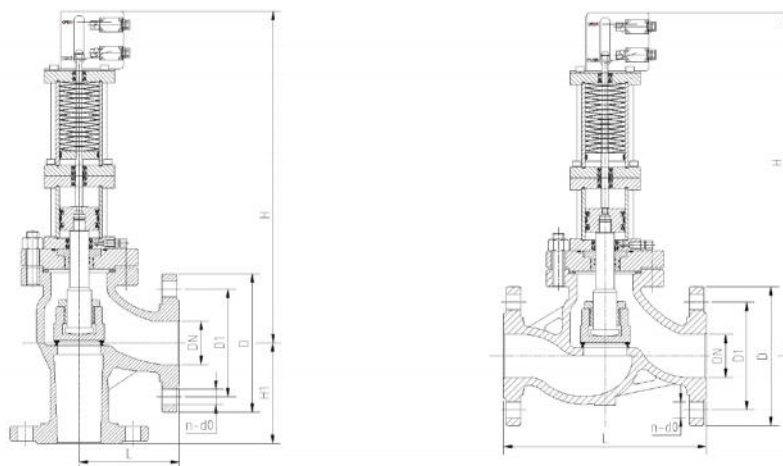

外形及连接尺寸 SHAPE AND CONNECTING DIMENSIONS (mm)															
通径 DN	结构尺寸 CONSTRUCTION DIMENSTON						法兰 FLANGE								液压执行器 HYDRAULIC ACTUATOR
	L		≈H		H1	φ	GB2506-2005 PN10				JIS 10K				
	A TYPE	B TYPE	A TYPE	B TYPE	B TYPE		D	D1	n	d0	D	D1	n	d0	
DN20	150	95	623	618	95	200	105	75	4	14	100	75	4	15	HAL40
DN25	160	100	628	623	100	200	115	85	4	18	125	90	4	19	HAL40
DN32	180	105	638	628	105	200	140	100	4	18	135	100	4	19	HAL40
DN40	200	115	653	643	115	200	150	110	4	18	140	105	4	19	HAL63
DN50	230	125	698	688	125	200	165	125	4	18	155	120	4	19	HAL70
DN65	290	145	708	703	145	200	185	145	4	18	175	140	4	19	HAL70
DN80	310	155	718	714	155	200	200	160	8	18	185	150	8	19	HAL80
DN100	350	175	789	784	175	250	220	180	8	18	210	175	8	19	HAL100
DN125	400	200	824	814	200	280	250	210	8	18	250	210	8	23	HAL100
DN150	480	225	861	856	225	320	285	240	8	22	280	240	8	23	HAL100
DN200	600	275	973	963	275	360	340	295	8	22	330	290	12	23	HAL130
DN250	730	325	918	898	325	450	395	350	12	22	400	355	12	25	HAL150
DN300	850	375	938	928	375	500	445	400	12	22	445	400	16	25	HAL200

电液式单作用截止阀ELECTRO HYDRAULIC SINGLE ACTING CUT-OFF VALVE

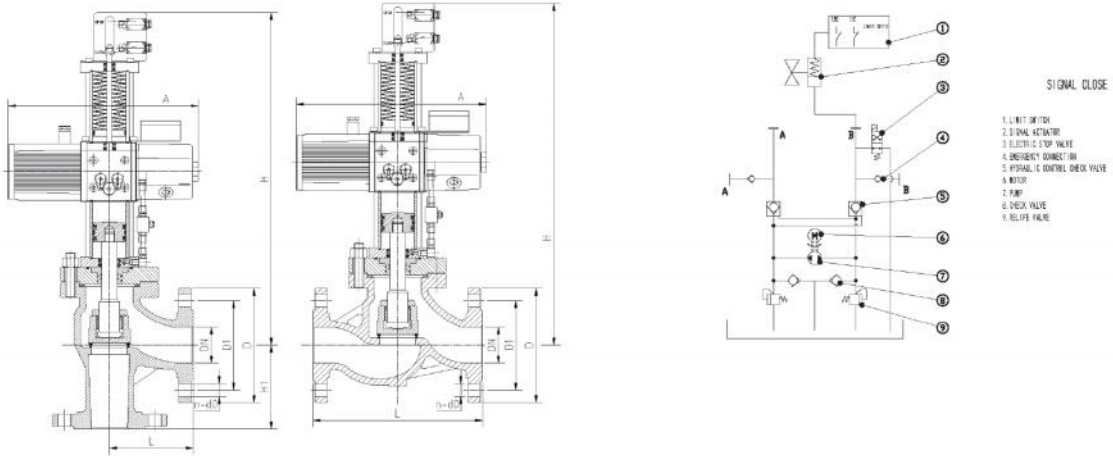

外形及连接尺寸SHAPE AND CONNECTING DIMENSIONS (mm)															
通径DN	结构尺寸 CONSTRUCTION DIMENSTON						法兰 FLANGE								液压执行器 HYDRAULIC ACTUATOR
	L		≈H			A	GB2506-2005 PN10				JIS 10K				
	A TYPE	B TYPE	A TYPE	B TYPE	B TYPE		D	D1	n	d0	D	D1	n	d0	
DN20	150	95	623	618	95	338	105	75	4	14	100	75	4	15	HAL40
DN25	160	100	628	623	100	338	115	85	4	18	125	90	4	19	HAL40
DN32	180	105	638	628	105	338	140	100	4	18	135	100	4	19	HAL40
DN40	200	115	653	643	115	338	150	110	4	18	140	105	4	19	HAL63
DN50	230	125	698	688	125	338	165	125	4	18	155	120	4	19	HAL70
DN65	290	145	708	703	145	338	185	145	4	18	175	140	4	19	HAL70
DN80	310	155	718	714	155	338	200	160	8	18	185	150	8	19	HAL80
DN100	350	175	789	784	175	338	220	180	8	18	210	175	8	19	HAL100
DN125	400	200	824	814	200	338	250	210	8	18	250	210	8	23	HAL100
DN150	480	225	861	856	225	338	285	240	8	22	280	240	8	23	HAL100
DN200	600	275	973	963	275	338	340	295	8	22	330	290	12	23	HAL130
DN250	730	325	918	898	325	338	395	350	12	22	400	355	12	25	HAL150
DN300	850	375	938	928	375	338	445	400	12	22	445	400	16	25	HAL200

气动截止阀PNEUMATIC CUT-OFF VALVE

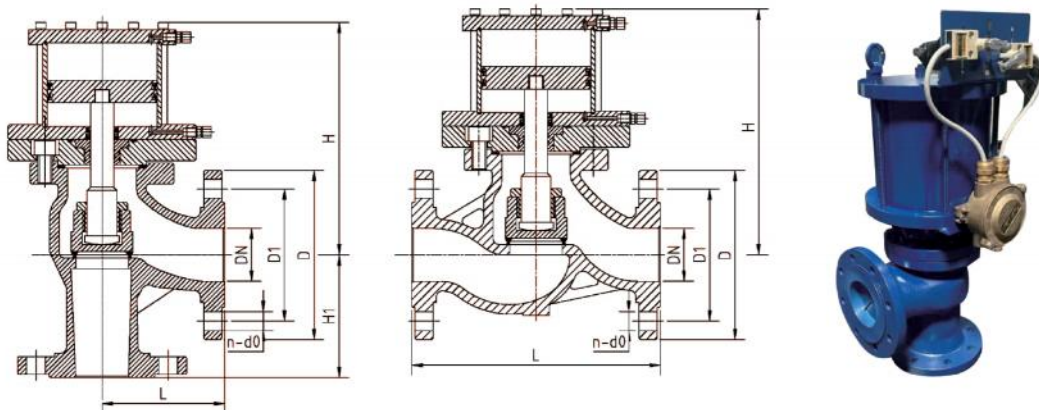



液动执行器

外形及连接尺寸 SHAPE AND CONNECTING DIMENSIONS (mm)

通径DN	结构尺寸 CONSTRUCTION DIMENSTON					法兰 FLANGE							
	L		≈H		H1	GB2506-2005 PN10				JIS 10K			
	A TYPE	B TYPE	A TYPE	B TYPE	B TYPE	D	D1	n	d0	D	D1	n	d0
DN20	150	95	385	380	95	105	75	4	14	100	75	4	15
DN25	160	100	390	385	100	115	85	4	18	125	90	4	19
DN32	180	105	400	390	105	140	100	4	18	135	100	4	19
DN40	200	115	415	405	115	150	110	4	18	140	105	4	19
DN50	230	125	420	410	125	165	125	4	18	155	120	4	19
DN65	290	145	430	425	145	185	145	4	18	175	140	4	19
DN80	310	155	440	430	155	200	160	8	18	185	150	8	19
DN100	350	175	455	450	175	220	180	8	18	210	175	8	19
DN125	400	200	470	460	200	250	210	8	18	250	210	8	23
DN150	480	225	480	475	225	285	240	8	22	280	240	8	23
DN200	600	275	515	505	275	340	295	8	22	330	290	12	23
DN250	730	325	530	510	325	395	350	12	22	400	355	12	25
DN300	850	375	550	540	375	445	400	12	22	445	400	16	25

手气动截止阀 MANUAL PNEUMATIC CUT-OFF VALVE

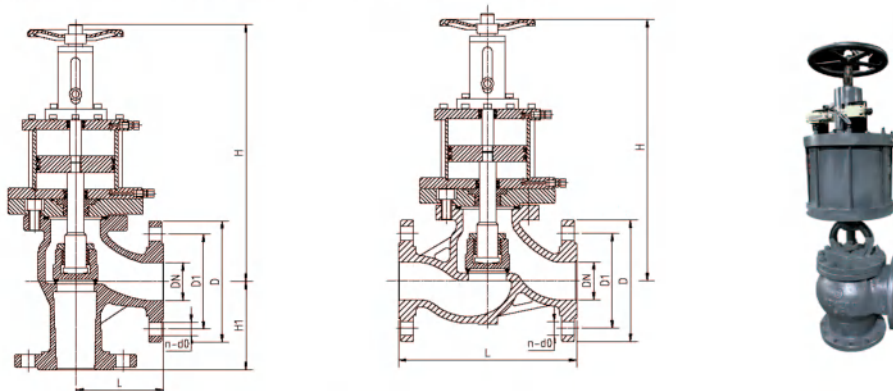

外形及连接尺寸 SHAPE AND CONNECTING DIMENSIONS (mm)

通径DN	结构尺寸 CONSTRUCTION DIMENSTON					φ	法兰 FLANGE							
	L		≈H		H1		GB2506-2005 PN10				JIS 10K			
	A TYPE	B TYPE	A TYPE	B TYPE	B TYPE		D	D1	n	d0	D	D1	n	d0
DN20	150	95	635	650	95	200	105	75	4	14	100	75	4	15
DN25	160	100	640	635	100	200	115	85	4	18	125	90	4	19
DN32	180	105	650	640	105	200	140	100	4	18	135	100	4	19
DN40	200	115	660	655	115	200	150	110	4	18	140	105	4	19
DN50	230	125	670	660	125	200	165	125	4	18	155	120	4	19
DN65	290	145	680	675	145	200	185	145	4	18	175	140	4	19
DN80	310	155	690	680	155	200	200	160	8	18	185	150	8	19
DN100	350	175	705	700	175	250	220	180	8	18	210	175	8	19
DN125	400	200	720	710	200	280	250	210	8	18	250	210	8	23
DN150	480	225	760	755	225	320	285	240	8	22	280	240	8	23
DN200	600	275	815	805	275	360	340	295	8	22	330	290	12	23
DN250	730	325	860	840	325	450	395	350	12	22	400	355	12	25
DN300	850	375	910	900	375	500	445	400	12	22	445	400	16	25

手气动单作用截止阀MANUAL PNEUMATIC SINGLE ACTING CUT-OFF VALVE

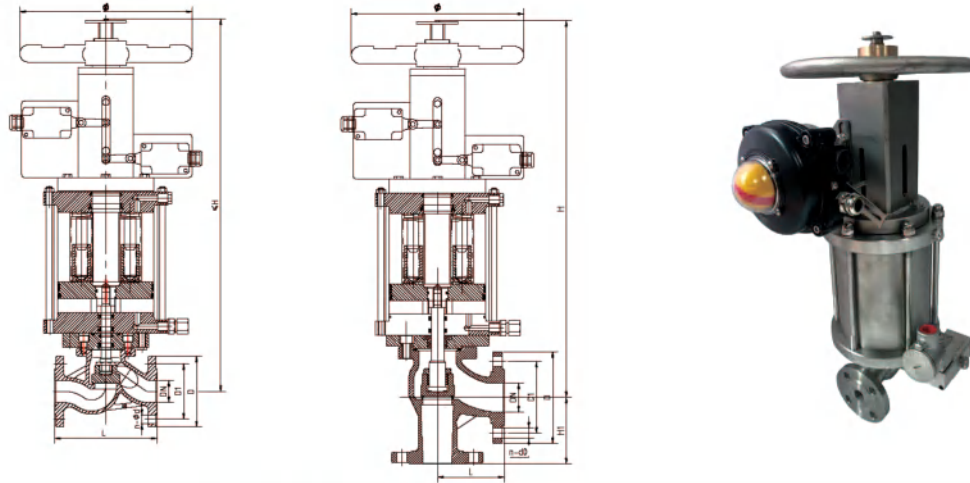

外形及连接尺寸SHAPE AND CONNECTING DIMENSIONS (mm)

通径DN	结构尺寸 CONSTRUCTION DIMENSTON						法兰 FLANGE							
	L		≈H		H1	φ	GB2506-2005 PN10				JIS 10K			
	A TYPE	B TYPE	A TYPE	B TYPE	B TYPE		D	D1	n	d0	D	D1	n	d0
DN20	150	95	510	505	95	200	105	75	4	14	100	75	4	15
DN25	160	100	520	515	100	200	115	85	4	18	125	90	4	19
DN32	180	105	580	575	105	200	140	100	4	18	135	100	4	19
DN40	200	115	610	655	115	200	150	110	4	18	140	105	4	19
DN50	230	125	670	660	125	200	165	125	4	18	155	120	4	19
DN65	290	145	720	715	145	200	185	145	4	18	175	140	4	19
DN80	310	155	770	765	155	200	200	160	8	18	185	150	8	19
DN100	350	175	800	790	175	250	220	180	8	18	210	175	8	19
DN125	400	200	800	790	200	280	250	210	8	18	250	210	8	23
DN150	480	225	900	890	225	320	285	240	8	22	280	240	8	23
DN200	600	275	1100	1090	275	360	340	295	8	22	330	290	12	23
DN250	730	325	1350	1340	325	450	395	350	12	22	400	355	12	25
DN300	850	375	1400	1390	375	500	445	400	12	22	445	400	16	25

液动闸阀HYDRAULIC GATE VALVE

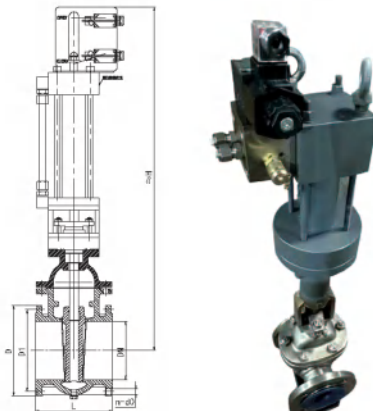

通径DN	结构尺寸 CONSTRUCTION DIMENSTON		法兰 FLANGE								液动执行器 HYDRAULIC ACTUATOR
	L	≈H	GB2506-2005 PN10				JIS 10K				
			D	D1	n	d0	D	D1	n	d0	
DN50	178	950	165	125	4	18	155	120	4	19	HAL40
DN65	190	970	185	145	4	18	175	140	4	19	HAL40
DN80	203	1000	200	160	8	18	185	150	8	19	HAL63
DN100	229	1060	220	180	8	18	210	175	8	19	HAL63
DN125	254	1120	250	210	8	18	250	210	8	23	HAL63
DN150	267	1160	285	240	8	22	280	240	8	23	HAL63
DN200	292	1230	340	295	8	22	330	290	12	23	HAL80
DN250	330	1350	395	350	12	22	400	355	12	25	HAL100
DN300	356	1400	445	400	12	22	445	400	16	25	HAL130